

# Blind Spot Detection in Automobile

Yash Vispute, Prajakta Jakate, Aniket Bhor, Prof. Vineeta Philip



Electronics and Telecommunication Department,  
AISSMS Institute of Information Technology, Savitribai Phule Pune University, Pune, India

## ABSTRACT

Nowadays, number of accidents is increasing especially the side collision of the vehicles when the driver tries to change the lane to either to left or right. When driving a vehicle on a road, if a driver wants to change lane, he must glance the rear and side mirrors of his vehicle and turn his head to scan the possible approaching vehicles on the side lanes. However, the view scope by the above behaviour is limited; there is a blind spot area invisible. To avoid the possible traffic accident during lane change, we here propose a blind spot detection system which detects a car or objects with the help of ultrasonic sensor and display the distance between the object and car on dashboard which helps to avoid accidents. For this system we will use PIC controller and interface it with ultrasonic sensor and mainly to avoid complexity of wiring we will use CAN protocol.

**Keywords**— blind spot detection system; ultrasonic sensor; PIC; CAN.

## ARTICLE INFO

### Article History

Received: 8<sup>th</sup> March 2020

Received in revised form :

8<sup>th</sup> March 2020

Accepted: 10<sup>th</sup> March 2020

**Published online :**

11<sup>th</sup> March 2020

## I. INTRODUCTION

The blind spot monitor is a vehicle-based sensor device that detects other vehicles located to the driver's side and rear. Warnings can be visual, audible, vibrating, or tactile. However, blind spot monitors are an option that may do more than monitor the sides and rear of the vehicle [1]. They may also include "Cross Traffic Alert", which alerts drivers backing out of a parking space when traffic is approaching from the sides.

The origin of the field bus was to replace any point-to-point links between the field devices and their controllers by a digital single link on which all the information is transmitted serially and multiplexed in time. We prefer serial transmission because of his merits over a parallel transmission [3]. There are two types of communication system used in the security and control system of industries which are Field bus control system and Distributed control system. Among these two systems, the field bus control system is a solution of process control with advantages in standardization in network communication. It has simple structure, higher accuracy and higher anti disturbance capability than the distributed [2].

Controller Area Network (CAN) bus is a type of field bus system. Control type decentralization, intelligence and networking. CAN protocol was designed by Robert Bosch for automotive applications as a method for enabling robust serial communication [4]. The goal was mainly to make automobiles more reliable, safe and fuel efficient. With all these advantages, the use of CAN bus in a monitoring system is increases the value of the system and also increases its reliability. The purpose of CAN bus is to enable any point to communicate with other point without putting too much load on their main controller [5]. CAN bus is a fast serial bus that is designed to provide an efficient, highly reliable and cost effective link between various CAN stations, sensors and actuators and other parts of the system.



Fig. 1 Blind spot

## II. METHODOLOGY

### A. System Design

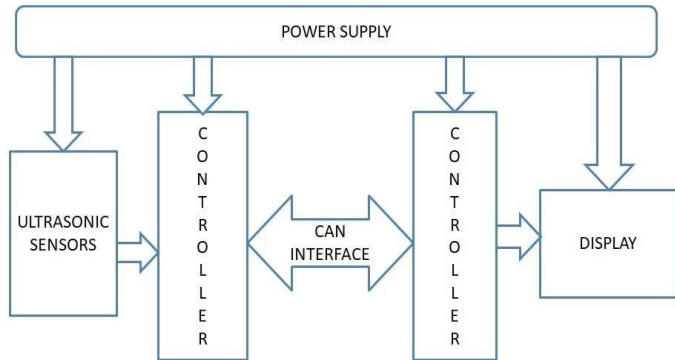

Fig. 2 Block diagram

The fig. 2 shows the block diagram of the blind spot detection system which will be attached to the dashboard of the vehicle and front side of the vehicle. The system will consist of the PIC18F4550, HCSR04 Ultrasonic sensor, MCP2515, LCD which will warn the driver about the distance between two vehicles. MCP2515 CAN controller will be attached to reduce the complexity of wires.

### B. System development

The system encompasses of the PIC microcontroller, ultrasonic sensor and CAN bus controller.

The microcontroller that is chosen to be used is PIC microcontroller since it has more advantages. It includes C compiler optimized architecture instruction set, linear program memory addressing up to 32Kbytes and data memory up to 4 Kbytes. It provides 16-bit wide instructions, 8-bit wide data path, 4 external interrupt pins with Priority levels, High current sink/source 25 mA/25mA, 4 timer modules with 8 bit timer/counter, In-Circuit Serial Programming (ICSP) via two pins. Fig. 3 depicts the PIC microcontroller.

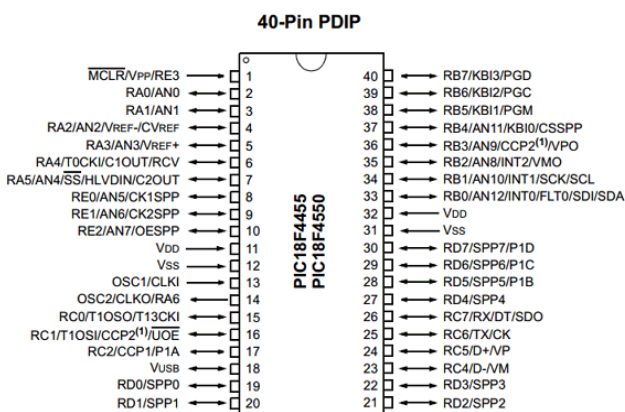

Fig. 3 PIC18F4550

CAN protocol is generally a message-based protocol, not an address based protocol. This means that messages are transmitted from one node to another node. All nodes in the system receive every message that is transmitted on the bus (and will acknowledge if the message was properly received). It is up to each node in the system to decide whether the message received should be immediately discarded or kept to be processed. A single message can also be destined for one particular node to receive, or many other nodes based on the way the network and system are designed.



Fig. 4 MCP2515

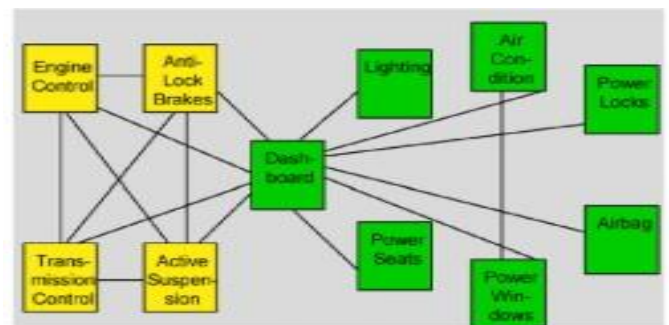

Fig. 5 Without CAN

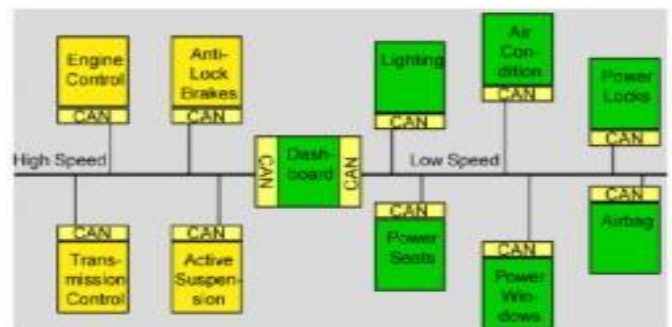

Fig. 6 With CAN

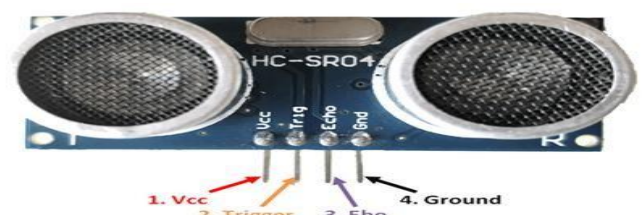

Fig. 7 HCSR04

C. Technical specification

1. Ultrasonic Sensor - HCSR04 - Measuring Angle: 15 degree, Working Frequency: 40Hz.
2. PIC18F4550 - Microchip PIC 18F4550 with 20 MHz Crystal Oscillator (With Boot loader Software), supports USB V2.0 with Speed range from 1.5Mbps to 12Mbps, 32 KB Programmable Flash Memory.
3. MCP2515 - Up to 1Mb/s bus speed, Up to 1000 meter bus length.

III. SIMULATION RESULTS

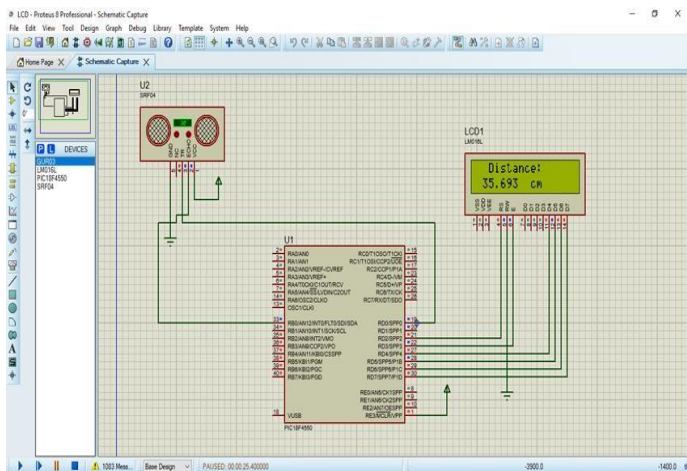

Fig. 7 Simulation result

Interfacing of PIC18F4550 controller with different peripherals like microcontroller, HCSR04, LCD 16X2 is done. The simulation for same is done in PROTEUS8 soft-ware. For simulation Ultrasonic sensor is interface with PIC controller and sensing distance is displayed on LCD 16x2 alphanumeric LCD.

IV. RESULTS

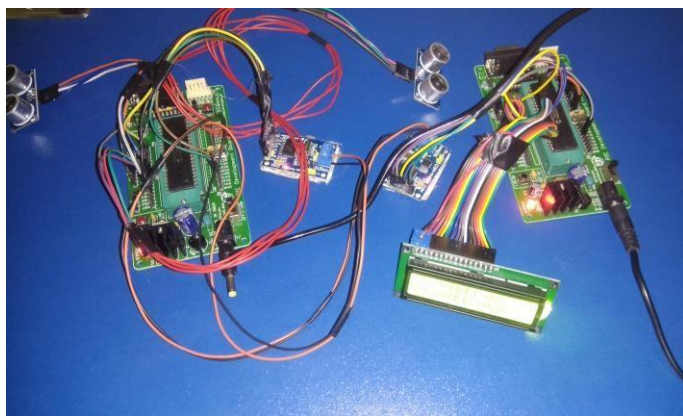

Fig. 8 Result

V. CONCLUSION

The project presents a real-time embedded blind spot safety assistance system to detect the vehicle or motor cycle appearing in the blind spot area.

REFERENCES

[1] A Radar-based Blind Spot Detection and Warning System for Driver Assistance. (Guiru Liu<sup>1</sup>, Lulin Wang<sup>2</sup>, Shan Zou<sup>1</sup> 1. College of Computer and Information Science, Anhui Polytechnic University. 2.Prospective Technology Research Institute, Chery Automobile Co., Ltd-Wuhu, China - 2017)

[2] Developing intelligent blind spot detection system for Heavy Goods Vehicles-(Pasy Pyykonen, Ari Virtanen, Arto Kyytinen.- 2015)

[3] Robust Vehicle Detection and Tracking Method for Blind Spot Detection System by using Vision Sensors - Seunghwan Baek Heungseob Kim and Kwangsuck Boo\* High Safety Vehicle Core Technology Research Center Inje University.2014)

[4] A Warning System for Obstacle Detection At vehicle Lateral Blind Spot Area (Jiann-Der Lee and Kuo-Fang Huang Department of Electrical Engineering, Chang Gung University,Tao-Yuan, Taiwan - 2013 7th Asia Modelling Symposium)

[5] Active Blind Spot Crash Avoidance System A Haptic Solution to Blind Spot Collisions-(David P. Racine, Nicholas B. Cramer, and Mehrdad Hosseini Zadeh The Department of Electrical & Computer Engineering Kettering University Flint, MI, USA -2010)